

阿瓦赫 Z2 系列产品

# 用户说明书

## User's Manual

AWAH Z2 Series



版本：V2.0

产品名称	阿瓦赫 Z2 多功能滑轮
Product Name	Drill-Powered Pulley
型号 /Model	AWAH Z2 / AWAH Z2-R
产品类型	上升器 / 下降器 / 滑轮
Product Types	Ascender/Descender/Pulley
执行标准	XF 494—2004
Execution Standards	
语言 Language	中文简体 English

# User's Manual

## AWAH-Z2 Drill-Powered Pulley

**Please read the manual and understand the contents before using the device.**

**Please keep this instruction manual safe and available to record any repairs or maintenance done on the unit.**

This manual describes techniques and methods for correct product use. Please pay extra attention to the warning signs, which identify the potential hazards and special precautions for using this product. These warnings are not exhaustive, for more information or updated versions of instructions please visit the company's website or the WeChat official account. It is the user's responsibility to read all instructions and use this product correctly, any misuse will cause safety risks. If you have any questions or do not fully understand this manual, please contact us.

## Declaration of Conformity

AWAH-Z2 Drill-Powered Pulley has been tested and qualified according to the following standards.

NO.	Standards	Product type	Inspection and testing Report number
1	XF 494—2004	Ascender	GTFWT20230149
2	XF 494—2004	Descender	GTFWT20230148
3	XF 494—2004	Pulley	GTFWT20230410G

Artisans Working At Heights Co., Ltd.  
March 20, 2023

# Contents

<b>1 Responsibilities and warnings</b>	<b>32</b>
<b>2 Product introduction</b>	<b>33</b>
2.1 Product's illustrations	33
2.2 Product Introduction	44
2.3 Scope of use	44
2.4 Technical specifications	45
2.5 Compatible parts	46
<b>3 Safety Rules</b>	<b>47</b>
<b>4 Operating Instructions</b>	<b>49</b>
4.1 Load the rope	49
4.2 Install a backup system	49
4.3 Lifting	50
4.4 Lowering	50
4.5 Rope retraction	51
<b>5 Device checks</b>	<b>52</b>
5.1 Check before use	52
5.2 Inspection during use	53
5.3 Inspection regularly	53
5.4 Scrap assessment	54
<b>6 Storage and maintenance</b>	<b>56</b>
<b>7 Limited Warranty</b>	<b>57</b>
<b>8 Packing list</b>	<b>58</b>
<b>9 Repair record sheet</b>	<b>59</b>
<b>10 Table for record inspections</b>	<b>60</b>
<b>11 Table for usage record</b>	<b>61</b>

# 1 Responsibilities and warnings

Any work involving the use of this product is dangerous. Users are responsible for and bear the consequences of their actions, decisions, and safety. Do not use this product if you cannot assume responsibility or cannot fully understand this manual.

## 1.1 Before using this product, you must:

- Read and understand this user's manual completely.
- Take specific training for the proper use of this product in a safe environment.
- Familiarize yourself with this product, understand its performance, the restrictions of using and emergency disposal methods.
- Understand and accept the dangers involved.

1.2 This product is intended for use only by competent and responsible personnel or under direct visual supervision by competent and responsible persons.

1.3 Ignoring any of these warnings can result in damage to property, serious injury, or even death.

1.4 The company does not assume any responsibility for any direct or indirect results such as property damage or personal injury or death caused by the use of this product.

1.5 It is recommended to purchase commercial insurance for users and goods to cover property damage or personal injury or death caused by possible operational errors.

## 1.6 Illustrations' descriptions



## 2 Product introduction

### 2.1 Product's illustrations

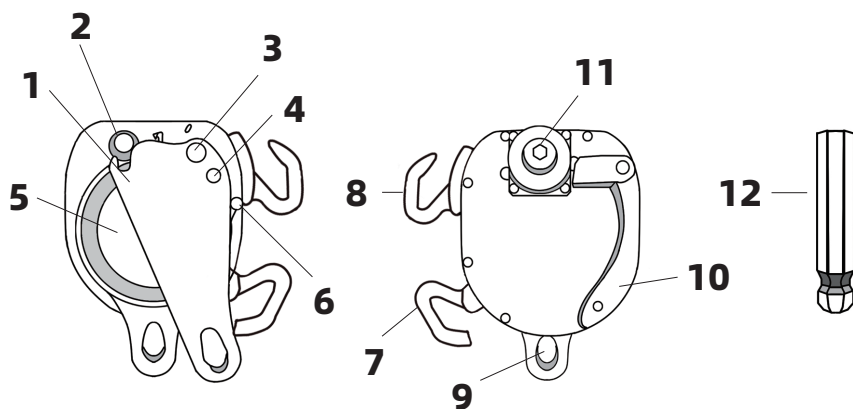

- |                           |                                    |                                |
|---------------------------|------------------------------------|--------------------------------|
| ① Movable side panel      | ② Wheel for guiding rope #1        | ③ Wheel for guiding rope #2    |
| ④ Wheel for pressing rope | ⑤ Wheel for winding rope           | ⑥ Friction bar                 |
| ⑦ Friction hook #1        | ⑧ Friction hook #2                 | ⑨ Main attachment hole         |
| ⑩ Handle for Releasing    | ⑪ Electric drill adapter interface | ⑫ Electric drill adapter shaft |

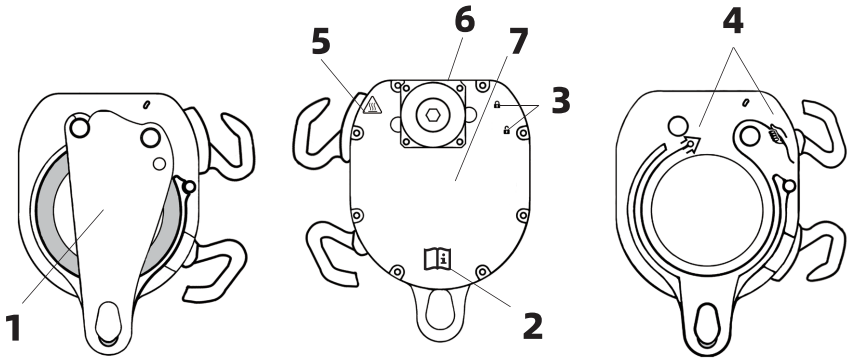

- ① Name & Model
- ② Read the manual before use
- ③ Indication of correct position
- ④ Indicate of the rope direction
- ⑤ Hot scald tip
- ⑥ Serial Number
- ⑦ Specifications

23 C 00 00 0000-XXXX

year of manufacture	—	—	—	—	—	— identifying code
month of manufacture	—	—	—	—	—	— serial number
day of manufacture	—	—	—	—	—	— batch number



Beware: falling objects, risk of mechanical injury, high equipment



Designed for  $10.5 \leq \Phi \leq 11$  mm kernmantle ropes (sheath + core). Certain 9mm to 10.5mm ropes can be used but beware: if the rope is too thin or too soft, it is easy to twist into the wheel, and you have to cut the rope. No twisted rope or cable allowed.



Oval carabiners only. GB/T 23469、EN 362



hammers



wrenches  
impact drills  
screwdrivers

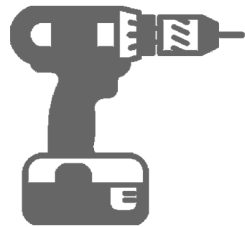

Torque: 50 ~ 150 N•m / 450-1300 in-lbs. **NO IMPACT DRILL**





Send it back to the manufacturer for repair. Do not repair yourself.

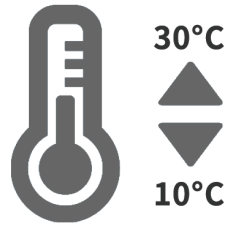

Store in a cool and dry environment. Avoid heavy pressure, drops, and dust.



Do not wash at high pressure or with corrosive substances.

**Figure 1** Indication of correct position

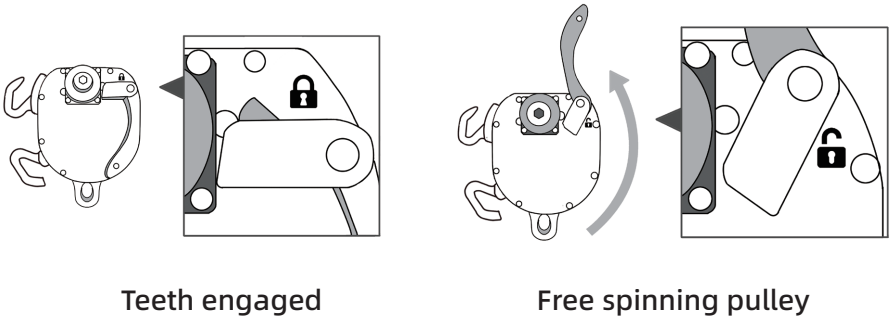

**Figure 2** Do not load over an edge

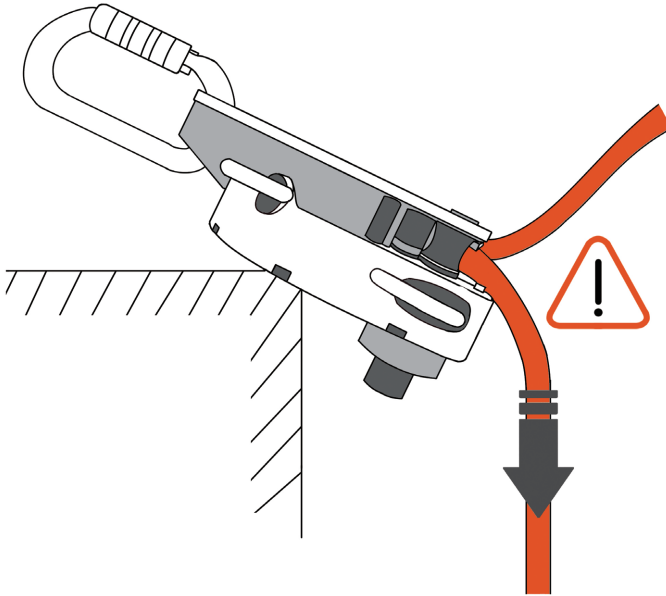

**Figure 3** Ensure the side panel is closed

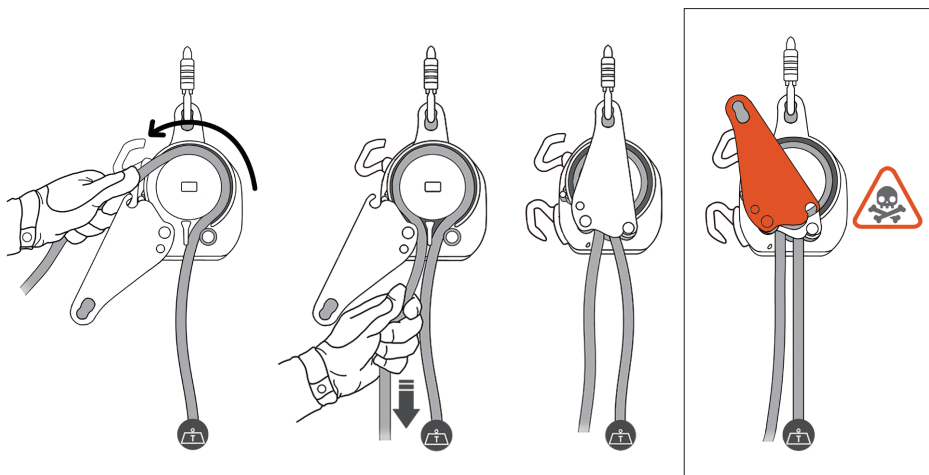

Be sure the front plate is closed and clipped with carabiner

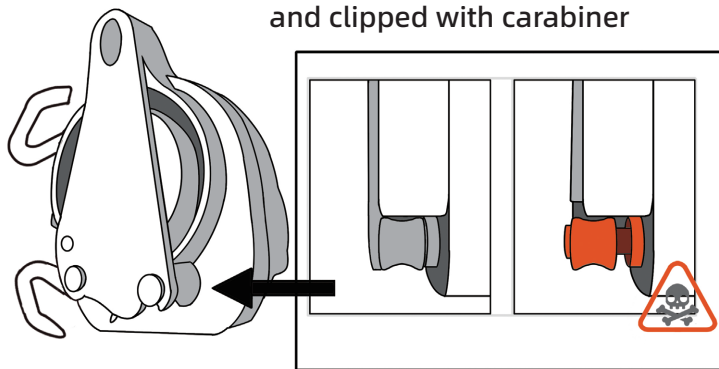

Figure 4 Functional checks

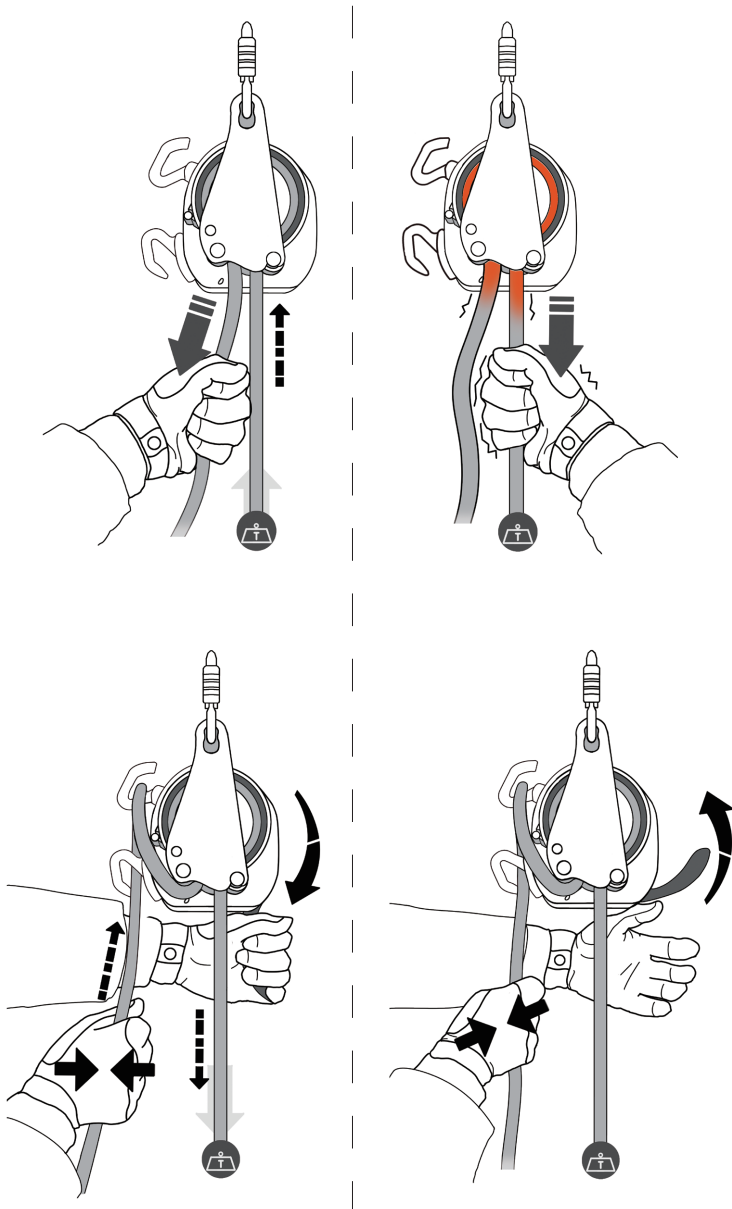
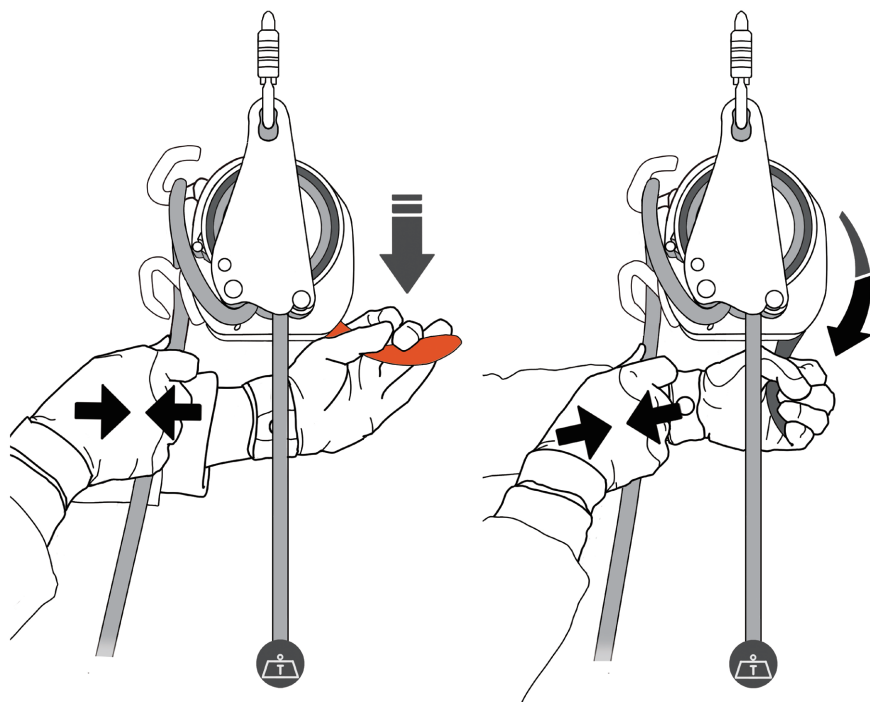

Figure 5 Normal lowering



**DO NOT PULL THE HANDLE SLOWLY. Pull it quickly.**

When the handle is unlocked, the internal ratchet is unhooked and the wheel for winding rope instantly becomes a high-efficiency pulley. Therefore, before pulling the handle, be sure to wrap the rope on the friction hook to obtain sufficient friction, and the greater the weight to lowering, the more turns the rope needs to be wrapped.

**Figure 6** Warnings of hand-off and incorrect grip

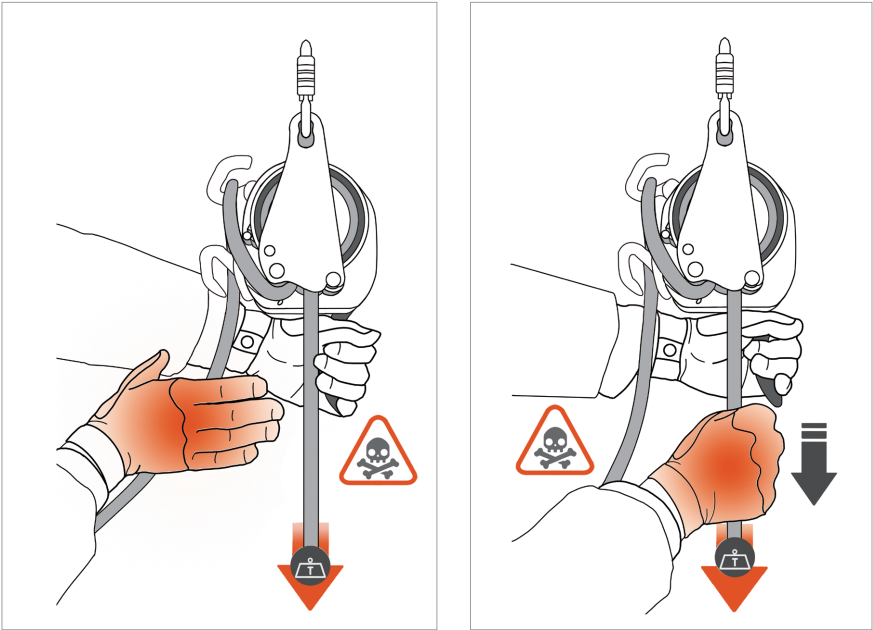

**Figure 7** Manual lifting and electric lifting

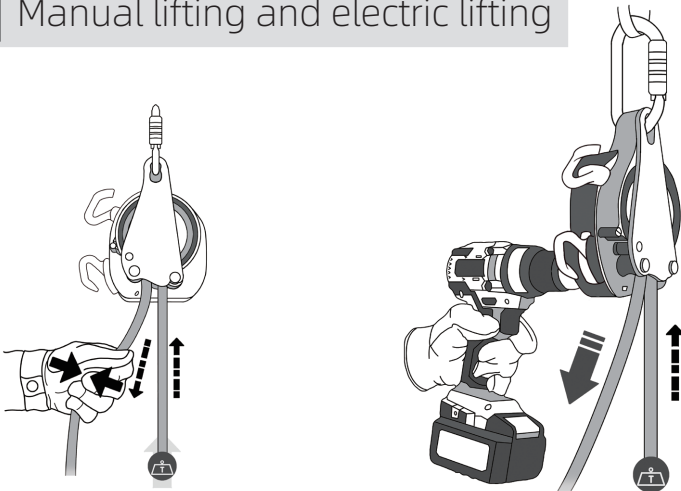
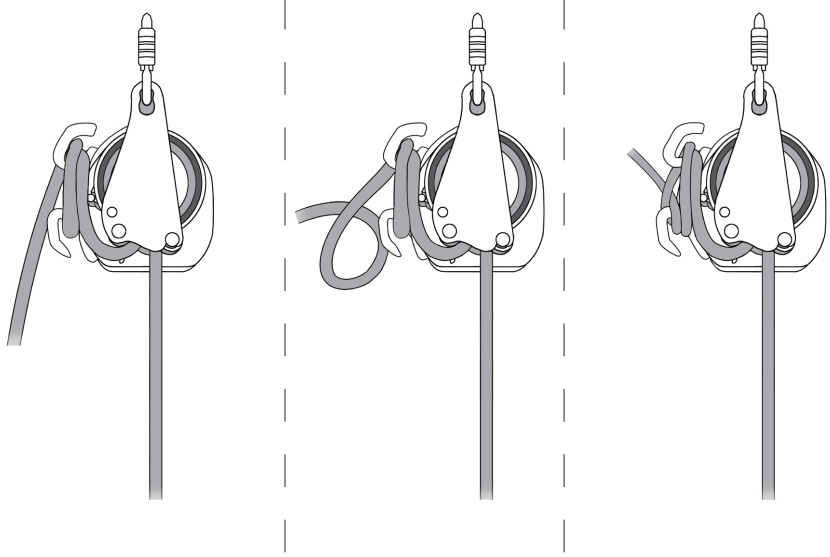
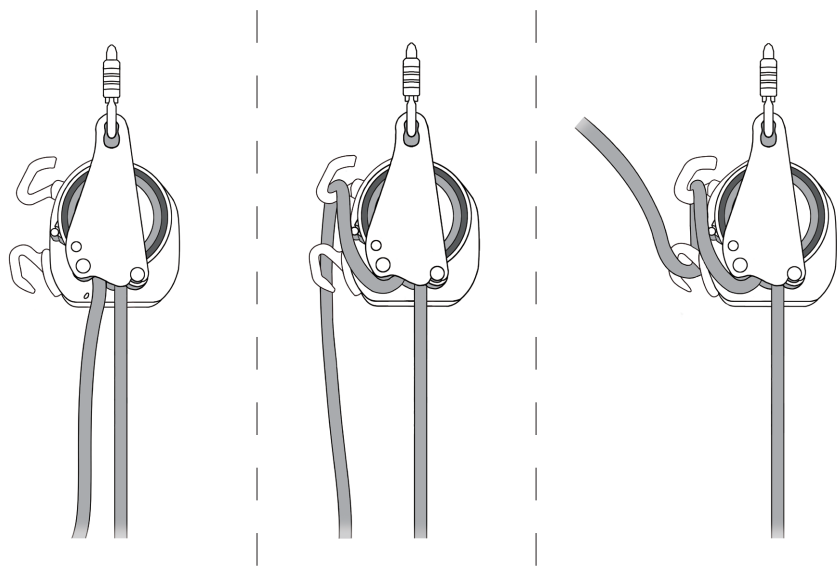
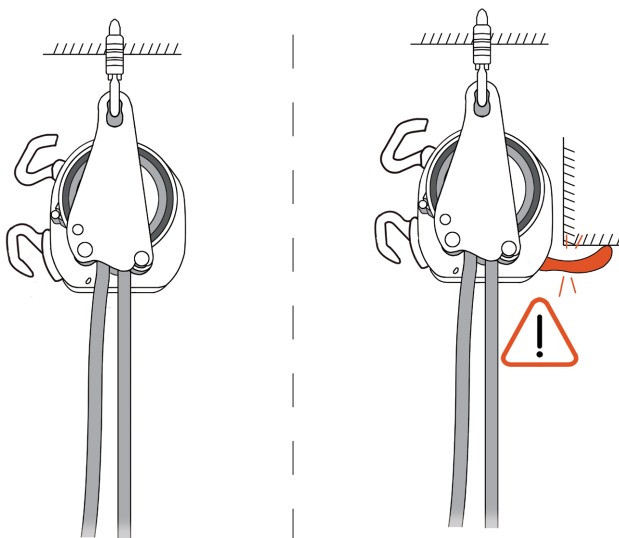

Figure 8 Locking off the rope



**Figure 9** Make sure handle operation is not obstructed.



**Figure 10** **Must** be used with a backup system **(Z2 / Z2-R)**

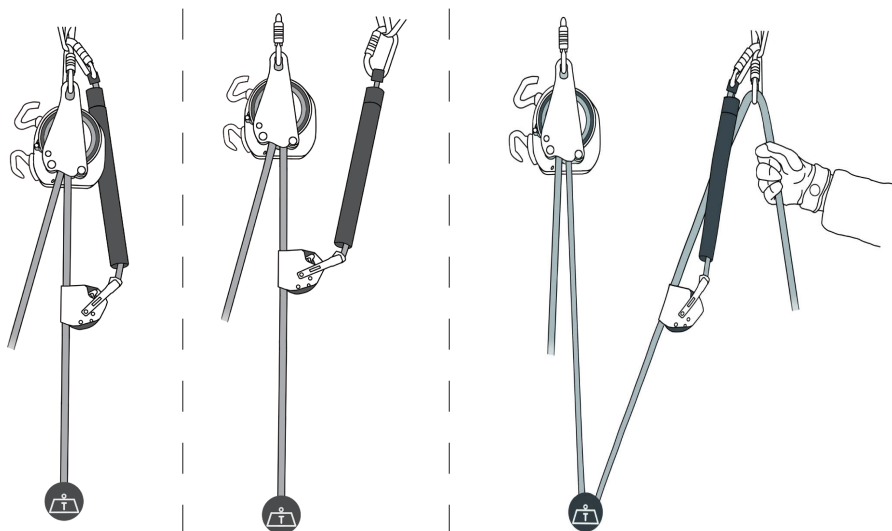



## 2.2 Product Introduction

AWAH-Z2 is a drill-powered pulley, integrating a progress capture pulley, gears for assisted lifting, and friction arms to be a descender. It can be connected to an electric drill to provide lifting power. This unit allows for efficient assistance in lifting and lowering goods or personnel **WHEN USED WITH A BACK UP DEVICE.**

## 2.3 Scope of use

2.3.1 This product is mainly used to lift or lower goods or personnel. The core component of this product is a releasable unidirectional pulley, which can be used alone as a fixed pulley or combined with additional pulley(s) to form an appropriately mechanical advantage System.

2.3.2 This product is equipped with a hexagonal interface and an adapter shaft (8 mm or 5/16"). To lift weight, use an electric drill to turn the adapter shaft counter-clockwise. This product only supports manual descent. It does not support descent by electric drill power.

2.3.3 This product should only be used in a dry environment. It is not waterproof or dustproof. Use in environments with chemical hazards such as seawater or corrosive liquids and gases will lead to a reduced product lifespan. This can cause safety hazards, the product should not be used in the above environments.

## 2.4 Technical specifications

Specifications \ Models	Z2	Z2-R
Execution standards	XF 494–2004 Fire Rescue Industry Standards of China	
Product Types	Pulley / Ascender / Descender	
Weight	2.34 kg	2.37 kg
Load Range	30 kg ~ 150 kg	30 kg ~ 200 kg
Second Attachment Hole	No	Yes
Additional Handle (For comfort)	Yes	No
Gear Ratio	100:10	100:12
Rope Type & Diameter	Kernmantle Ropes / $\Phi 9 \sim 11$ mm	
Torque of Electric Drill	50 ~ 150 N·m / 450 - 1300 in-lbs No Impact Brushless Drill Recommended	
Descent Speed Limit	0.5 m/s (Max Load) ~ 2.0 m/s (Min Load)	
Lifespan of Lifting	$\leq 20,000$ meters	
Lifespan of Lowering	$\leq 20,000$ meters	
Anti drop Height	$\leq 1$ meter	
Operating Temperature	- 15°C ~ 45°C / 5 °F ~ 113 °F	
Dust and Waterproof	No	
Lifespan	Either 6 years after the date of manufacture, or lifting by 20,000 meters or lowering by 20,000 meters, whichever condition comes first shall prevail.	

## 2.5 Compatible parts

2.5.1 The anchor devices connected to this product shall meet the requirements of GB 30862, EN 795 or higher performance.

2.5.2 The connectors connected to this product shall meet the requirements of GB/T 23469, EN 362 or higher performance and shall be oval in shape.

2.5.3 The harnesses connected to this product should meet the corresponding category or higher performance requirements of GB 6095, EN 358, EN 813, EN 361, etc. according to the different usage scenarios.

2.5.4 The electric drills connected to this product should meet the torque requirements in section 2.4. It is strictly forbidden to use electric hammers, electric wrenches, impact drills, screwdrivers and other power tools with rotary impact or radial impact functions. Do not use the impact gear setting of electric drills. **The shock function will damage the power input shaft gear of this product, resulting in damage to the equipment.**

2.5.5 This product works best with EN 1891A ropes with a diameter between 10.5~11 mm. Typical materials for the manufacture of such ropes are polyamide or polyester or a mixture of both. The best rope structure is when the sheath tightly wraps the core. A stiff rope feeds out of the pulley better. The thickness of the rope directly affects the load that this product can carry, that is, the thinner the rope, the more likely it is to slide under lower loads. The use of spiral ropes, wire ropes, flat belts (ropes) or chains is forbidden.



Note 1: The lifting power of this product comes from the friction between the rope and the wheel, so it is inevitable that the rope will be worn; The greater the load, the faster the rope will wear out. The longer it is used, the more wear and tear the rope will see.



Note 2: The life of this product is usually longer than that of the rope, so frequently check the condition of your ropes and replace them if there are signs of wear. The life of ropes varies greatly depending on the quality, refer to the information provided by the rope manufacturer to assess when the rope should be scrapped.

## 3 Safety Rules

**The user should have the corresponding theoretical knowledge and practical ability of working at height, and must read and understand this manual completely, and master the working principle, use essentials, performance characteristics, use restrictions and emergency disposal methods of this product, in order to help safe operation.**

3.1 When using this product, do not use anchor devices, connectors, harnesses or ropes that do not meet the requirements of this manual. Strictly limited to use within the nominal load range. Overloaded use will shorten the life of this product, accelerate rope damage and electric drill wear. Serious overload may damage the equipment during one use (including damage to the main body of the equipment, damage to components such as attachment holes, friction hooks, handle, power input shafts, and compatible parts such as ropes, connectors and electric drills).

3.2 Users who suffer from any physical illness, psychological disorder, or drug dependence that may affect safe operation may pose a hazard, such as: high blood pressure, heart disease, dizziness; acrophobia; binge drinking; sudden illness during work, etc. If you feel unwell, please immediately stop working with this product.

3.3 Before use, a sufficiently wide isolation area should be set up. Supervision should be arranged, and unrelated personnel should be prohibited from entering the work area to prevent being injured by falling objects or the work system from being damaged by someone.

3.4 Users should take protective measures in advance. Correctly wear harnesses, gloves, helmets, goggles, shoes and other PPE suitable for the nature of work that meet relevant standards. This prevents accidents such as falling from height, electric shock, extrusion, impact, and rope breakage.

**3.5 When lifting or lowering goods or personnel, this product must be accompanied by a personal protective equipment (PPE) backup safety system, as shown in Figure 10.**

3.6 To prevent damage to personnel, goods, ropes, and this product, do not obstruct the path of lifting and descending.

3.7 The friction bar and friction hook of this product may produce high temperature during use or just after use. **Heat accumulation will cause the braking performance to deteriorate, and may melt the rope.** If the temperature gets too hot, it can be cooled with water, but DO NOT STOP MOVING THE ROPE THROUGH THE DEVICE. The rope will be melted if exposed to the high temperature for too long at the same spot. The rope should be removed immediately after use and this product should be left to rest until cooled, otherwise it may cause burns and damage to the rope.

3.8 In the normal use of this product, friction bar, friction hooks, wheel, attachment hole, power input shafts, as well as connectors and ropes will gradually wear. Always inspect the device before use. In-use inspection, regular inspection, and scrap assessment all help to eliminate potential safety hazards.

3.9 This product is not intended for fall arrest. Overloading can damage the rope.

# 4 Operating Instructions

## 4.1 Loading the rope

- (1) Attach this product to the anchor device(s) with reliable connectors.
- (2) Open the movable side panel and load the rope.
- (3) Close the movable side panel and snap it into the connector.
- (4) Check to make sure the handle is in the locked position.



Note: The movable side panel of this product has a closed hole, the connector needs to be removed to load and remove the rope. Be very careful not to drop the product when handling.

## 4.2 Install a backup system

Figure 10 shows three modes of backup systems, with enhanced security from left to right. A fall arrest system or rope clamp that complies with the relevant standards or is certified is recommended. The backup system on the left shares the anchor devices with this product; On the middle, the anchor devices of the backup safety system is independent; On the right, the backup system uses a two-rope system, and any rope (and related components) failure has a backup guarantee.

Warning 1: The amount of slack in the backup system should be as small as possible to reduce the impact of the fall. The backup system should have a certain degree of flexibility to cushion the impact of the fall.

Warning 2: The load to be lifted or lower should be within the allowable range of the backup system, and overload use will be a safety risk.

Warning 3: There should be adequate clearance distance under the backup safety system to prevent hitting obstacles or the ground when falling.

## 4.3 Lifting

4.3.1 Lifting manually. If this product is attached to the upper anchor point, and after the rope is properly loaded, it can be used as a one-way pulley to manually lift weight.

4.3.2 Lifting by electric drill. This product only supports the counterclockwise rotation of the electric drill to input power to lift.

Warning: When using an electric drill to lift, always ensure that the release handle is in the locked position to prevent the goods or personnel from falling.

4.3.3 When the attachment hole is connected to the user's harness, This product can lift the user and move up with him/her; When the attachment hole is connected to the anchor point, this product does not move with the user and can be used with other pulley (s) to lift remote goods or personnel.

## 4.4 Lowering

4.4.1 When the attachment hole is connected to the user's harness, this product can be used as a personal descender to lower the user himself; When the attachment hole is connected to the anchor point, this product is used to lower goods, or as a manual descender to rescue personnel.

4.4.2 Prepare for lowering.

- (1) Load the rope correctly;
- (2) Check to ensure that the handle is in the locked position;
- (3) The control end of the rope is wrapped around the friction hook with maximum friction and locked.

4.4.3 Descent steps.

(1) Ensure that the control end of the rope is wrapped around the friction hook with maximum friction and is locked;

(2) The left hand **quickly** pulls the release handle to the bottom and keeps it in the release position;

(3) The right hand gradually and slowly unties the rope from the friction hook, and in the process of untying, the right hand grasps the control end

of the rope, and it is strictly forbidden to let go freely;

(4) The user begins to descend slowly after obtaining appropriate friction; during the descent, the right hand maintains control of the control end of the rope, and it is strictly forbidden to take off the hand;

(5) To pause the descent, wrap the rope around the friction hook with maximum friction and lock it, and pull the release handle to the locked position.

(6) In case of emergency, the release handle can be quickly and completely released to allow it to quickly rebound back into the locked position to quickly stop the descent, but it is not recommended to use this method frequently due to possible impact on the product, rope and anchor device(s).

**Warning:** If there is an obstacle within the range of activity of the release handle, it may cause it to not automatically rebound to the locked position, and there is a risk of falling.

## **4.5 Rope retraction**

This product can assist in rope retrieval quickly. Load the rope into this product, then connect electric drill to quickly retrieve the free rope.



# 5 Device checks

## 5.1 Check before use

Before using this product, inspect and test that you have the correct rope, correct connecting components, and that the backup system is functioning properly.

5.1.1 Check whether this product has deformation, corrosion, cracks, severe wear, sharp surfaces, etc. If any, stop using it immediately, and contact the manufacturer for technical support.

5.1.2 Check the cleanliness of components such as wheels, friction bar, friction hooks, etc. If the above friction components have grease, it will reduce the friction, resulting in the accidental fall of goods or personnel. If the above friction components have grains of sand, it will cause rapid wear and tear.

5.1.3 Check whether the rope is broken, the rope sheath is broken, partially thickened, partially raised, partially dented, severely fuzzy, excessively hardened, excessively soft, entangled, knotted in the middle, or dirty. Make sure the rope has a clear history of use and no contact with substances (oils, acids, alkalis, unknown chemicals, etc.) that may weaken the performance of the rope. If the above situation occurs, the rope should be replaced with a new rope without safety hazards, and the above inspection should be performed before use too.

5.1.4 If the noise of gear has significantly increased when running, abnormal jitter, unable to input power to lift, unstable work or stuck, etc., it may indicate that the ball bearings and gears of the equipment are worn excessively. Stop immediately and contact the manufacturer for technical support.

5.1.5 If the power input shaft teeth are found to be striped, slipped

or other phenomena, the use of the lifting function should be stopped immediately and contact the manufacturer for technical support. This indicates that the power input shaft is worn.



**Note:** Other connecting components are also necessary for systematic safety, please refer to the information provided by the relevant manufacturer to check as required.

5.1.6 Before official use, at least 1 lifting and lowering test of goods should be taken. It is recommended that the lifting height is not more than 30 cm / 12 inches. Pay attention to listen to whether the "click" sound emitted by the ratchet working is a little crisp and loud. If the sound is not normal, the equipment may be faulty and should immediately stop being used. Contact the manufacturer for technical support.

## 5.2 Inspection during use

5.2.1 During the lifting process, pay close attention to the abnormal situation of the equipment in accordance with the requirements of 5.1.5 and 5.1.6.

5.2.2 During the descent process, the temperature of the friction bar and friction hooks should be paid close attention in accordance with the requirements of 3.7.

## 5.3 Inspection regularly

Carry out as comprehensive inspection every 6 months. In addition to the pre-use inspection items, the following items should be checked:

5.3.1 Check the friction components, if the wear is excessive, it should be scrapped in time or contact the manufacturer for repair and replacement.

5.3.2 The inside of this product has been lubricated. If the running noise increases significantly, or the ratchet tapping sound changes from low to very crisp, please fill with the manufacturer's approved grease. If a large amount of oil leakage is found, please contact the manufacturer for technical support.

Position	Original size	Safety margin
Friction bar	Diameter: 8 mm	≥ 4 mm
Friction hook #1	Diameter: 10 mm	≥ 8 mm
Friction hook #2	Diameter: 10 mm	≥ 8 mm



**Note:** For basic maintenance (adding grease) and basic repair (replacing input shaft), the user may remove the small square area on the back where the hex driver bit is entered. The large back panel and large main gear need to be repaired by the manufacturer. **DO NOT REMOVE.**

5.3.3 Check the moving parts and springs of the release handle. If they are stuck, clean them thoroughly and apply lubricating grease.

5.3.4 Check all fixing bolts of the product. If they protrude above the mounting surface, they are loose. Use an electric screwdriver to tighten them. If the bolts loosen repeatedly, add a small amount of low-temperature anaerobic glue, tighten them, and let stand and solidify before use.

5.3.5 Check the input shaft gear of the product, and replace it if it is excessively worn. For evaluation and replacement methods, please visit our website.

## 5.4 Scrap assessment

A comprehensive inspection should be carried out every 12 months, and in addition to the regular inspection items, the following items should be checked:

5.4.1 The main structure of this product is metal, stored in a dry, cool, sealed and non-corrosive liquid and corrosive gas environment, the theoretical life is 6 years after production.

5.4.2 The amount of wear of the wheel. The nominal minimum diameter rope and the nominal maximum working load are used for

testing, the weight is suspended stationary and the release handle is in the locking position, the control end of the rope does not bear the tension and does not increase friction around the rope, or if the rope slides slowly in the wheel, the whole machine should be scrapped.

5.4.3 The user should record and analyze the lifting and lowering load, running distance and other data, and recommend scrapping after exceeding the nominal allowable range. If assessed for continued use, more rigorous pre-use inspections, in-use inspections, and periodic inspections at shorter intervals should be performed. Please refer to the technical specifications of this product for the service life of this product:

- manually lowering rated max load 200 times, 100 meters each time, for a total of 20,000 meters;
- electric lifting rated max load 200 times, 100 meters each time, for a total of 20,000 meters;
- the life of lifting and lowering do not affect each other.

5.4.4 If there is any doubt about the security of the device, you should immediately stop using it and contact the manufacturer for technical support.

## 6 Storage and maintenance

**Good storage and maintenance can extend the life of this product.**

6.1 This product is suitable for storage in an environment of 10°C ~30°C / 50 °F ~90 °F , to avoid water ingress, moisture, corrosive liquid and corrosive gas erosion, to avoid heavy pressure and falls from height.

6.2 During transportation, a bag or box with a cushioning capacity should be used to protect this product from severe impact, contact with sediment and dust, etc., and transported according to the requirements of storage conditions.

6.3 After each use, this product should be wiped clean with a clean fresh wet towel, and then ventilated to dry, not exposed to the sun, to avoid sweat and other corrosive liquids staying on the surface for a long time and causing corrosion.

6.4 The input shaft gear of this product can be replaced after wear or torque damage, provided that other parts are still available after inspection.

6.5 Any modification, replacement or repair of this product can only be carried out by the manufacturer, and self-disassembly, modification and repair are strictly prohibited.

## 7 Limited Warranty

**This product is a consumable. The manufacturer provides (one) year limited warranty for defects in the materials and production process of the product.**

The warranty does not cover damage to the product caused by wear, deformation, corrosion, oxidation, self-modification or repair, incorrect operation, improper storage and transportation, and other usage than for which it was designed. The input shaft components are wear parts and are not covered by the warranty.

**Tips: Please pay close attention to the information on the official website ([www.awah.cn](http://www.awah.cn)) , register the product on our WeChat official account, and keep your contact information open to ensure that you do not miss possible product defect recall notices.**

# Packing list



NO.	Name	Quantity	Remark
1	AWAH-Z2/Z2-R	1	
2	8 mm or 5/16" hex bit	1	
3	User's Manual	0	Please download the electronic edition from our website
4	Certificate of conformity	1	

# Repair record sheet



Device name:

SN:

NO.	Repair items	Repairer	Date
1	Replace the friction bar		
2	Replace the friction hook #1		
3	Replace the friction hook #2		
4	Fill with grease		
5	Replace the power input shaft		
6	The whole product is returned to the factory for maintenance		
7			



# Table for record inspections



Device name:

SN:

Location	Date	Inspector signature
<b>NO.</b>	<b>Detect items</b>	<b>Results</b>
1	The handle rebounds normally to the locked position	
2	The wheel locks when the rope is pulled on one side and turns when pulled on the other side	
3	Rotate the wheel slowly, you can hear a deep and even "click" sound	
4	The movable side panel can open and snap into the fixing pins normally	
5	The attachment holes are not deformed or cracked	
6	There is no serious oil leakage in the housing	
7	The body is free from corrosion, deformation, cracking, or wear	
8	Bolts, rivets, and other fasteners are not loose	
9	The remaining size of the friction bar and friction hooks is within the safety range	
10	The texts, marks etc. on the body are clearly legible	

Detection results

Note: The test result is "Normal", "Pending further inspection", "Repair required", "Scrapped".

# Table for usage record



Device name:

SN:

Date of use:

Usage Times	Lifting mass(kg/lbs)	Lifting height(m/ft)	Lowering mass(kg/lbs)	Lowering height(m/ft)	Remark
1					
2					
3					
4					
5					
6					
7					
8					
9					
10					
subtotal	Average kg/lbs	Total m/ft	average kg/lbs	Total m/ft	

# Table for usage record



Device name:

SN:

Date of use:

Usage Times	Lifting mass(kg/lbs)	Lifting height(m/ft)	Lowering mass(kg/lbs)	Lowering height(m/ft)	Remark
1					
2					
3					
4					
5					
6					
7					
8					
9					
10					
subtotal	Average kg/lbs	Total m/ft	average kg/lbs	Total m/ft	





**东莞市高新匠机电设备安装服务有限公司**  
Artisans Working At Heights Co., Ltd.

**[www.awah.cn](http://www.awah.cn)**

**[awah\\_cn@163.com](mailto:awah_cn@163.com)**